

A
material: brass
finish: nickel

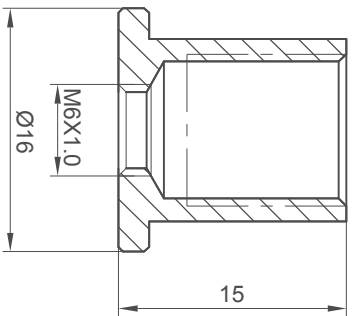

B
material: brass
finish: nickel

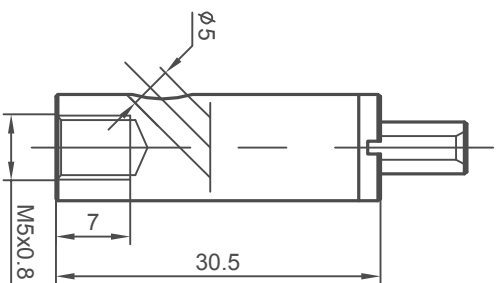
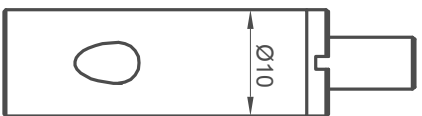
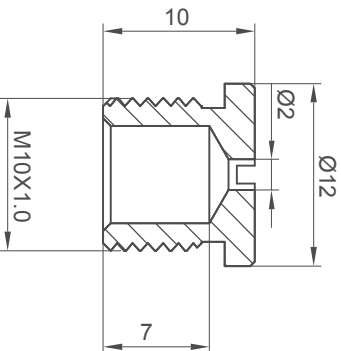

C
material: steel
finish: galvanized

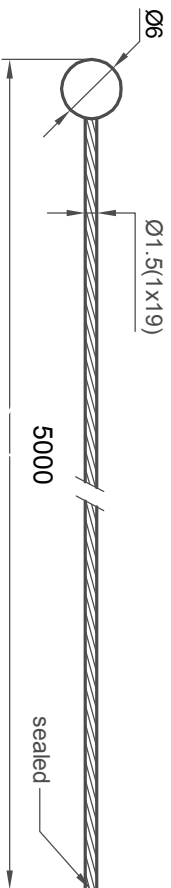

D
material: steel
finish: zinc

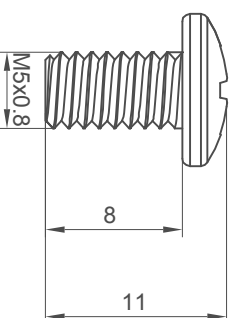

title: 1.5X5000MM SUSPENSION KITS
item number:

project reference: 140725-01(5000)

created by: jesse wang
tolerance: ISO2768-M

auditor:
scale: 1.5 : 1

approved by: jesse
dimension in mm

material: brass + steel
issue: A0

drawing code:

finish: nickel / zinc
date: JULY-30-2014

东莞市长安鸿拓五金厂
WIRE ROPE MATE HARDWARE CO.LTD